

# Contact Line Winch Type RWF 1500



Capstan winches used for contact-line laying or renewal have to meet widely varying requirements, such as high rope speeds on the one hand and an automatic and sensitive approach to the tensile limit of the contact line on the other hand.

Here again the **automatic pull hold-on (static pull) and pull preselection system**, common in pipe renewal winches, renders excellent pulling service. This feature allows the rope to be brought to the desired tension and be held in static pull condition for a long time as well as to increase or lessen the tension as desired.

If the operating lever is set to neutral or if operation is stopped by pressing the emergency switch or if the engine stalls, the multiple disk brake will apply, preventing the rope tension from slackening.



Specifications are subject without notice. Output details are depending on use conditions.

# Bagela<sup>®</sup>

# Contact Line Winch Type RWF 1500



## Standard design:

- Single axle chassis with overrunning and automatic reversing brake system, straight tow-bar with ball type coupling, 12 V lighting system and TÜV-approval
- Lockable, sound proofed sheet metal hood
- Hydraulic pulling force measuring clockwork
- Working hour counter
- Diesel engine with hydrostatic gear system
- Twin capstan system with rope storage drum and 1500 m braided rope
- Pull hold-on system with pulling force preselection system
- Multiple disk brake
- Painting: traffic red RAL 3020

## Extras: (on request)

- other types of engines, painting or rope lengths
- Electronic printer with adjustable pull limiting switch
- Order No. 110.500.90**
- Telescopic deflection boom

Dimensions and weights may differ if extras are fitted.

## Technical data:

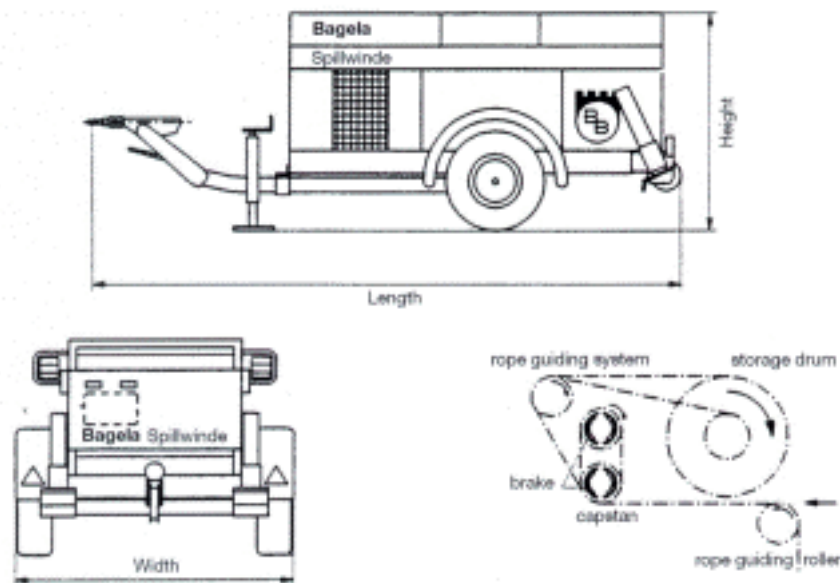

-o single-straight

-o single-height-adj.

-oo tandem-straight

-oo tandem-height-adj.

Type	Max. pulling		Drive engine			Rope		Chassis		Length	Width	Height	Weight	Lift-load	Order No.
	force	speed	kW	fuel	cyl.	diam.	length	type	brake						
<b>RWF 1500</b>	15 kN	70 m/min	12	petrol	2 A	8 mm	1500 m	-o	overrun	3200 mm	1650 mm	1300 mm	1400 kg	1,5 t	<b>001.001.70</b>

Specifications are subject without notice. Output details are depending on use conditions.